

# FORWARD DRUM DUMPER FORK CLAMP

Pads slip onto forks to convert this versatile pallet fork clamp into an on-demand dumper attachment. Positive dumping speed control allows precise handling of awkward materials.

Quick disconnect hydraulic couplings and security locks are standard features. Installation and removal takes just minutes.

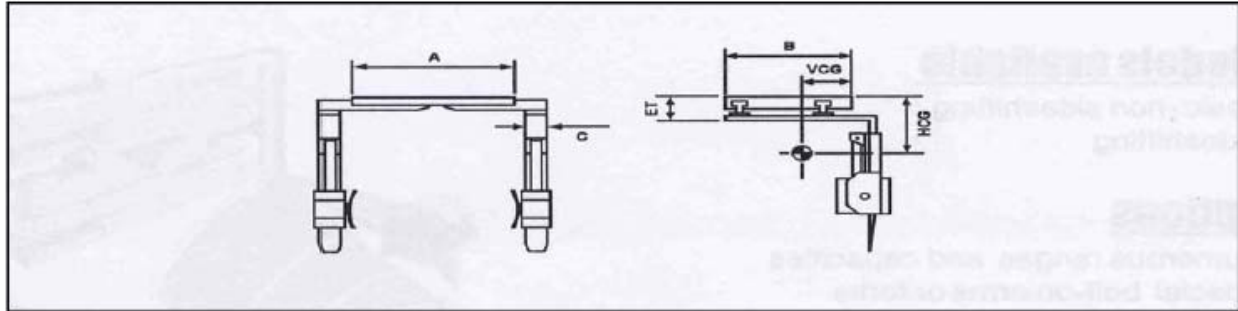

MODEL	CAPACITY LB @ 20" LC	TIP ANGLE	MIN-MAX OPENING IN.	AET	HCG	MOUNTING CLASS	WEIGHT LB	SIDESHIFT
11LD39GBX	1700	180	15-50	5-96	9.5	ITA I	924	NO
11LD39GSX	1700	180	15-50	5-96	9.5	ITA I	925	YES

Please Note: Non-sideshifting model requires two hydraulic functions. Sideshifting model requires three hydraulic functions. A solenoid valve adaption can be supplied to multiply the number of functions. Please contact ULH for the specific arrangement and desired set-up configuration for the application.

**Accurate, controlled dumping of liquid or powder materials into hoppers or bins. Fully inverts to 180 degrees for complete pour or for inverting drums.**

This forward tipping drum clamp combines the versatility of a standard drum clamp with a 180 degree forward rotation for dumping and inverting applications.

Engaged by two synchronized cylinders, a rack piston rod drives the hub pinion. This allows even, controlled dumping and inverting action.

The dumping pads and slip on arms are easily removed for normal clamping and positioning applications.

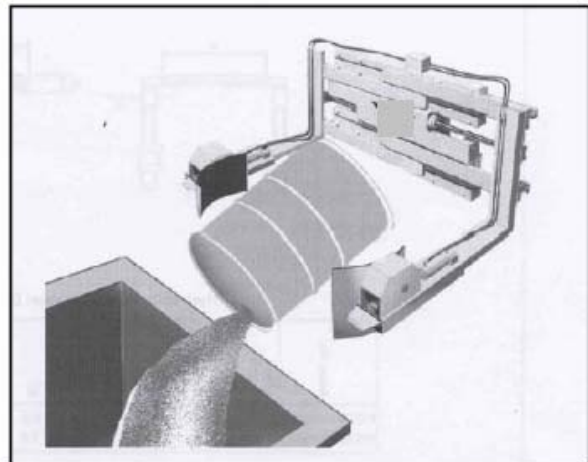

**Unit Load Handling Systems, Inc.**

2301 South Mission Circle, Friendswood, TX 77546

P: 281-992-2006 F: 281-992-2040 E: [bscally@earthlink.net](mailto:bscally@earthlink.net) [www.unitloadhandling.com](http://www.unitloadhandling.com)