



UNIT LOAD HANDLING SYSTEMS, INC.

HYDRAULIC BUCKET, FORK OR CARRIAGE MOUNTED



DUAL CYLINDERS

REINFORCED BACKWALL AND WEBBING STRUCTURE

HARDENED CUTTING EDGE

CAPACITIES FROM ½ CU YD UP TO 2.5 CU YD
REINFORCED CORNERS

HYDRAULIC CHECK VALVE HOLDS CYINDER POSITION

QUICK-DETACH FORK MOUNTED VERSION AVAILABLE

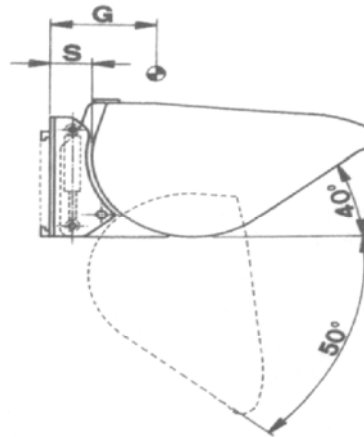
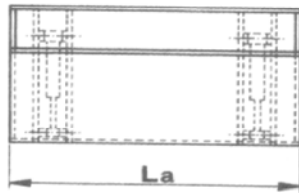

MODEL	CAPACITY	LA	WEIGHT	ITA CLASS
WHB1742	17 CU/FT	42 "	745 LB	II
WHB2048	20 CU/FT	48 "	780 LB	II
WHB2560	25 CU/FT	60 "	840 LB	III
WHB3072	30 CU/FT	72 "	880 LB	III
WHB3584	35 CU/FT	84 "	935 LB	III
WHFB55108	55 CU/FT	108 "	2250 LB	IV

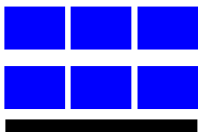

2301 South Mission Circle, Friendswood, TX 77546
PH: 281-992-2006 FAX: 281-992-2040

