

# T18R Rotating Overhead Cube Clamp

easily clamps and transports  
cubes of bricks, blocks or pavers

## Features

- Individual arm movement
- Self aligning cylinders
- Fully floating - two piece slide bushings
- Modular alloy steel construction
- Replaceable rubber faced pads

## Options

- Carriage mounted
- Equal arm movement
- Quick disconnect hydraulics
- Integral sideshift
- Slewing through 90 degrees in either direction

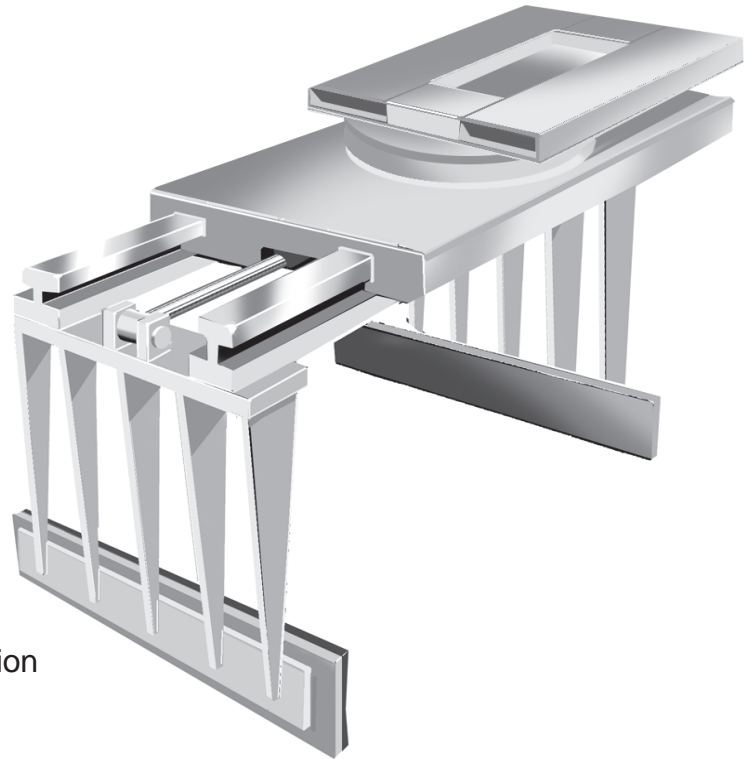

**Total Overhead Cube Clamps** can be mounted to the forks or carriage of any conventional forklift truck.

Cubes of bricks, blocks or pavers can be effortlessly clamped and transported for storage or shipping without incorporating expensive pallets.

By top-clamping the cube, spaces between columns of product can be dramatically reduced, especially when loading flatbed trailers or during yard storage.

The optional rotator also allows each cube to be placed in a specific orientation, once again conserving valuable space.

Turns a conventional pneumatic forklift  
into a specialized cube handler

